

MULTIDIRECTIONAL REACH TRUCK



ALL-STAR WIDE RECEIVER

- ▶ AC Drive and Lift Motors
- ▶ Articulating Load Wheels for Horizontal Travel
- ▶ Up to 4,500 lb. Capacity
- ▶ Auxiliary Fork Carriage Option
- ▶ 7" Color Touchscreen Display



RF1-MD1X45

CLASS
2

ELECTRIC MOTOR NARROW AISLE

ToyotaForklift.com

WIDE LOADS: HANDLED

WHEN IT COMES TO WAREHOUSING, wide loads and narrow aisles typically don't mix. Attempting to stack products like lumber, pipe, or carpet at right angles necessitates wider aisles that can put a hamper on your storage density and productivity.

Specially designed to handle wide, bulky loads, Toyota's Multidirectional Reach Truck provides an innovative alternative to traditional material handling. Articulating load wheels allow the forklift to travel horizontally, permitting compact travel and stacking wide loads in narrow aisles without the need to turn.

Operators can easily control and view load wheel placement and travel direction using the operator's display with directional and mode indicator lights. Combined with the easy-to-use multifunction control handle and open view mast, navigating wide loads through your bustling warehouse has never been easier.

IDEAL APPLICATIONS:

- ▶ Palletless Load Handling: Loads that are difficult or impractical to palletize, such as carpet or steel.
- ▶ Long Load Handling: Wide loads such as lumber and building supplies requiring wider aisles for right-angle stacking.
- ▶ Specialty Racking: Items stored in cantilever, push back, and other specialty racking for optimal storage and retrieval.





VERTICALLY INCLINED

THE MULTIDIRECTIONAL REACH TRUCK makes light work of more than just horizontal travel. The truck design provides great visibility and ergonomics when working in high racking. For extra assistance when working in tall racking, the optional carriage-mounted camera system feeds video of the forks and pallet to the standard 7" color touchscreen display for optimal control and precision. Optional Acculaser technology projects a light beam where the forks are positioned. The height and tilt indicator shows mast and fork positioning on the touchscreen display for even more precise load handling.

UP TO **22** FT.
WIDE LOADS

INTELLIGENTLY BUILT, COMFORTABLY PRODUCTIVE

The Multidirectional Reach Truck's intelligent design empowers operators to complete tasks confidently and efficiently, shift after shift. The single-axis, multifunction control handle allows simultaneous use of hydraulic functions and travel in one intuitive and ergonomic package. Rigid mast construction and an innovative suspension system help minimize mast sway for precise load handling at maximum lift heights.

An inertial dampener minimizes mast sway when right angle stacking at high lift heights for exceptional control and reduced product and racking damage.

EFFICIENCY TO KEEP YOU ON THE MOVE

Moving from pick to pick as quickly and efficiently as possible is the name of the game, and the Multidirectional Reach Truck delivers. Its powerfully efficient AC drive and lift motors offer superior acceleration, travel, and lift/lower speeds to maximize throughput while minimizing downtime. Regenerative plugging returns energy to the battery when plugging and coasting for more efficient operation and reduced energy costs.

WORK HARD, PLAY HARD

Built using the Toyota Production System, the Multidirectional Reach Truck exemplifies the quality, durability, and reliability you've come to expect from Toyota. When handling loads, you'll appreciate the solid reach mechanism design with anti-friction scissors, radial thrust bearings, and a torsion tube scissor tie that helps mitigate lateral stresses. Even our control handle, with only 35 parts and flex circuit technology, offers low-maintenance operation.

500^{HOUR}

PLANNED MAINTENANCE INTERVAL



TOYOTA MOVES WITH YOU



A NAME YOU CAN TRUST

Our material handling equipment carries something no others can: The Toyota name. As one of the most recognized and respected global brands, the Toyota name is synonymous with quality, durability, and value. It also provides a peace of mind that few companies of any kind can match.

Every Toyota Forklift is built using the world-renowned Toyota Production System (TPS), which features Just-in-Time parts delivery and quality checks at every step of the manufacturing process.

It's all part of the Toyota philosophy of "kaizen," the dedication to continuous improvement. Instituted by our founder more than 80 years ago, it's a principle that still guides us today. As long as our forklifts carry the Toyota name, we'll continue striving to improve processes and quality.

THE TOYOTA 360 SUPPORT PROMISE

In addition to moving more pallets more quickly through your facility, you can count on Toyota's dedication to quality and world-renown manufacturing methods to deliver unprecedented uptime and lower maintenance costs. Toyota 360 Support comes standard with every Toyota Reach Truck, meaning you benefit from an industry-leading two-year parts warranty, the support of over 65 dealerships, 3500+ Toyota Certified Technicians, and guaranteed 4-hour emergency response time.

65+
DEALERSHIPS

3500+
TOYOTA CERTIFIED TECHNICIANS

4-HOUR
GUARANTEED
EMERGENCY RESPONSE TIME

MULTIDIRECTIONAL REACH TRUCK

CAPACITY
4500 LBS.

LOAD CENTER
24 IN.

MAXIMUM FORK HEIGHT
268 IN.

INDUSTRIES



Building Supplies



Distribution



General Manufacturing



Lumber



Steel/Metals



Carpet



Factory



General Warehousing



Pipe

STANDARD EQUIPMENT

PERFORMANCE

- 36 Volt Electrical System
- AC Powered Drive System with Torque Control
- AC Hydraulic System
- Multifunction Control Handle
- Variable Speed Lift and Lowering
- Electric Power Steering Motor
- Two Speed Reach / Retract
- 7" Color Touchscreen Display Panel
 - Multifunctional Hour Meter
 - Time & Date Display
 - Programmable Travel, Acceleration, Lift/Lower Speeds, Reach/Retract & Coast Control
 - Fault Code Memory
 - Weight Display
- Current controlled proportional valve
- Lowering flow limiter
- Lift system relief valve
- UL "E" Construction

OPERABILITY

- 180-Degree Electronic Power Steering
- Multi-Directional Travel
- Auto-Position Hold
- Fore-Aft Stance Operator Compartment
- Open-View 3-Stage Mast (FSW)
- Hydraulically Cushioned Mast Staging
- Hydraulic Cushioned Retract System
- Hydraulic Fork Deceleration at Floor Level
- Polyurethane Drive Tire (13.5 in. dia. x 6.0 in.)
- Steerable Load Wheels (8 in. x 4 in.)
- Polyurethane Caster Wheel (8 in. x 4 in.)
- Electric Disc Brake
- Regenerative plugging
- Ventilated Tractor Compartment w/ Door Mounted High Capacity Cooling Fan
- 36 in Tilting Load Backrest Extension (4.5° Fwd / 3° Bwd)
- ITA Class II Hook-Type Carriage (48 in. Wide)
- Forks: 42 in. x 1.75 in. x 4 in.
- Anti-Static Ground Strap
- Proportional Handle Plugging
- Lift Slowdown at Max Lift
- Adjustable Speed Limit Above Freelif (0-3.5 mph)
- View-through Carriage

ERGONOMICS

- Bubble Cushioned Padded Floor & Brake Pedal
- Low Step Height
- Overhead Guard
- Safety Glass Mast Guard¹
- Comfort-Padded Lean Points
- Cushioned Knee Pad

SERVICEABILITY

- Battery Compartment Rollers
- Battery Retaining Gates (Adjustable)
- SB350 Gray Connector
- Battery Discharge Indicator w/ Lift Interrupt
- Self Diagnostics
- Built-In Analyzer
- Self-Adjusting Electric Disc Brake
- Emergency Power Disconnect Switch
- Electro-Mechanical Horn
- Key Switch
- Enclosed Battery Compartment:
 - 16.2 in. x 38.62 in. x 31 in.
 - 18.2 in. x 38.62 in. x 31 in.
 - 21.2 in. x 38.62 in. x 31 in.

¹ When the cold storage/freezer conditioning option is ordered, the safety glass mast guard is replaced with the wire mesh mast guard.

OPTIONAL EQUIPMENT

LOAD HANDLING

- Various Fork Length Options
- Forks Fully Tapered with Floor Lowered Height
- Custom Fork Lengths up to 48" (Specify Length)
- Less Forks
- Forks Lower to Floor Height
- Auxiliary Fork Carriage Options
- Tilting Load Backrest Extension Options
- Custom Mast Height (1 in. increments), Non-standard Overlap
- Custom Mast Height (1 in. increments), Standard Overlap
- Integral Sideshifter, 2 in. Each Way

BODY

- Full Height Mast Guard, Glass
- Wire Mesh Mast Guard, Partial Height
- Wire Mesh Mast Guard, Full Height
- Hinged Rear Operator Guard (partial length)
- Hinged Rear Operator Guard (full length)
- Overhead Guard Clear Shield
- Overhead Guard Mesh Shield
- Custom Overhead Guard Height
- Inertial Dampener
- Fire Extinguisher, 2.5 lb. Dry Chemical

WHEELS AND TIRES

- Various Drive Tire Options
- Caster Wheel, Smoothy®
- Poly Load Wheels, Smoothy®

LIGHTS, INDICATORS & MISC.

- LED Overhead Guard Mounted Work Lights (Pair)
- Operator Compartment LED Dome Light
- LED Travel Activated Work Lights (1 facing forward and 1 reverse)
- LED Amber Strobe Light
- LED Red Strobe Light
- LED Blue Strobe Light
- Special Mounting for Strobe Light (Bottom Mounted)
- Blue Spot Light, Key-on, Tractor First Only
- Blue Spot Light, Key-on, Both Directions
- All Travel Alarm
- Electronic Horn
- Crating for 107 in. OALH and Below

PRODUCTIVITY

- Various RF Bracket Options
- Power Hook-Up for On-Board Terminal (2 amp)
- Power Hook-Up for On-Board Terminal (10 amp)
- Acculaser (Red)
- Acculaser (Green)
- Camera System Cable
- Carriage-Mounted Camera System
- Height Indicator
- Height and Tilt Indicator
- Weight Height Limit Display
- Auto Height Select (Includes Reach Interlock Switch)
- Mast Lift Limit Switch w/ Bypass (1 in. increments)
- Mast Lift Limit Switch w/o Bypass (1 in. increments)
- Travel Speed Limit Switch
- Mechanical Lift Stop
- Reach Interlock Switch

OPERABILITY AND COMFORT

- Steer tiller friction block
- Steering Wheel Bar
- Reverse Steering
- Compartment Sensing System
- Compartment Sensing System for Cold Storage/Freezer
- Keyless On/Off Switch
- Electronic Key (Operator PIN Code Entry)
- Operator Compartment Fan
- Heated Handle and Floor

BATTERY ACCESSORIES

- Various Battery Connector Options
- 18.2 inch Battery Compartment
- 21.2 inch Battery Compartment
- Battery Side Gate Interlock
- Dual SBX Battery Connectors

SPECIAL MODELS

- UL Type "E" Rating
- Special Paint Color with Black Mast
- Cold Storage/Freezer Conditioning

MAIN VEHICLE SPECIFICATIONS

GENERAL DATA				MODEL NUMBERS		
				RF1-MD1X45		
Load Capacity ¹		lb (kg)		4500 (2043)		
Load Center		in (mm)		24 (600)		
Battery Compartment Size		in	16.2	18.2	21.2	
Power Type				Battery		
Operator Position				Stand-Up Rider		
EXTERIOR DIMENSIONS				RF1-MD1X45		
				BATTERY COMPARTMENT SIZE		
			16.2"	18.2"	21.2"	
A	Fork Lowered Height	in (mm)		3 (76)		
B	Maximum Fork Height (MFH) ¹	in (mm)		268 (6807)		
C	Free-Lift ¹	in (mm)		69 (1753)		
D	Tilt Range (forward / backward)	deg		3/4.5		
E	Mast Lowered Height	in (mm)		118 (2997)		
F	Mast Extended Height ²	in (mm)		304 (7722)		
G	Overhead Guard Height ¹	in (mm)		Contact Dealer		
H	Wheelbase	in (mm)	60.1 (1527)	62.1 (1577)	65.1 (1654)	
I	Battery Roller Height	in (mm)		7 (178)		
J	Bumper to Centerline of Drive Wheel	in (mm)		11.35 (288)		
K	Underclearance (center of wheelbase)	No Load	in (mm)	2 (51)		
L	Length to Fork Face (without sideshift)	in (mm)	56.3 (1430)	58.3 (1481)	61.3 (1557)	
M	Truck Length (Length to end of base legs)	in (mm)	76 (1930)	78 (1981)	81 (2057)	
N	Overall Truck Width	in (mm)		31 (787)		
O	Fork Size	T x W x L	in (mm)	1.75 x 4 x 42 (44 x 102 x 1607)		
P	Fork Spread (outer edge to edge)	Maximum / Maximum	in (mm)	24 - 48 (610 - 1219)		
Q	Base Leg Width	in (mm)		10 / 12 (254 / 305)		
R	Base Leg Inside Dimension (ID)	in (mm)		53.5 (1359)		
S	Base Leg Outside Dimension (OD)	in (mm)		75.5 (1918)		
T	Power Unit Width	in (mm)		42.5 (1080)		
U	Power Unit Height	in (mm)		51.5 (1308)		
V	Outside Turning Radius	in (mm)	82.5 (2096)	84.5 (2146)	87.5 (2223)	
	Basic Right Angle Stacking Aisle Width ¹			Contact Dealer		
	Carriage Height	in (mm)		36 (914)		
	Step Height	in (mm)		9.25 (235)		
PERFORMANCE DATA				RF1-MD1X45		
				BATTERY COMPARTMENT SIZE		
			16.2"	18.2"	21.2"	
Travel Speed ³	Maximum	mph (km/h)		7 (11.3)		
Suspension		Caster		Spring Loaded		
Gradability		%		7		
Grade Clearance	Loaded	%		12		
TRUCK WEIGHTS				RF1-MD1X45		
				BATTERY COMPARTMENT SIZE		
			16.2"	18.2"	21.2"	
Total Weight	Without Battery	lb (kg)		5650 (2701)		
TIRES				RF1-MD1X45		
				BATTERY COMPARTMENT SIZE		
			16.2"	18.2"	21.2"	
Tires	Tire Type	Drive / Caster / Load		Polyurethane		
	Number (x = driven)	Drive / Caster / Load		1x / 1 / 4		
	Size (dia. X width)	Drive	in (mm)		13.5 x 6 (343 x 152)	
Caster		in (mm)		8 x 4 (203 x 102)		
Load		in (mm)		8 x 4 (203 x 102)		
Brake Type				Electric Disc Brake		
POWER SYSTEM				RF1-MD1X45		
				BATTERY COMPARTMENT SIZE		
			16.2"	18.2"	21.2"	
Battery Type				Lead Acid		
Battery (6-hour ratings)	Compartment Size (Maximum)	Width	in (mm)	16.2 (412)	18.2 (463)	21.2 (539)
		Length	in (mm)		38.62 (981)	
		Height	in (mm)		31 (787)	
	Voltage / Capacity	Maximum	V / AH		36 / 1240	
Weight	Minimum	lb (kg)	2000 (907)	2300 (1043)	2600 (1179)	
	Maximum	lb (kg)	2300 (1043)	2600 (1179)	2900 (1315)	
Electric Motors	Drive	hp (kw)		7.1 (5.3)		
	Load Handling	hp (kw)		16.9 (12.6)		
ControlType	Drive			AC		
	Load Handling			AC		
	Power Steering	Loaded	%	Transistor		

1 Contact your local Toyota dealer for more information.

2 Add 8.5 in. (216 mm) for optional extended operator backrest.

3 Maximum speed provided is after break-in period. Values vary with truck weight, rolling resistance, mast height, options, and battery condition.

EXTERIOR DIMENSIONS

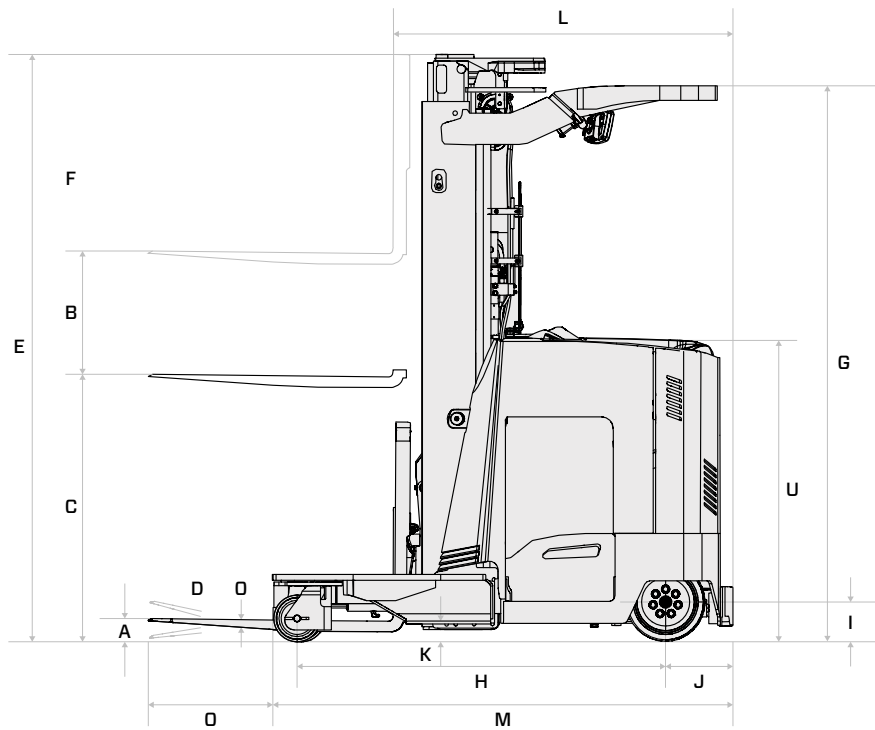
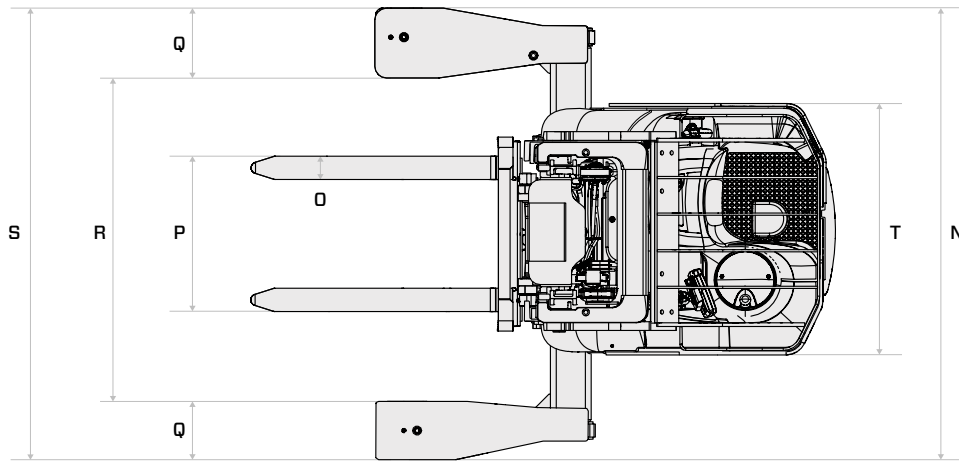

MAST SPECIFICATIONS

MAST TYPE	MAXIMUM FORK HEIGHT (TOP OF FORKS)	OVERALL HEIGHT		FREE LIFT	OVERHEAD GUARD HEIGHT	OVERHEAD COMPARTMENT HEIGHT	TILT RANGE ¹	
		LOWERED	EXTENDED WITH STANDARD 36" LOAD BACKREST	WITH STANDARD 36" LOAD BACKREST			FWD	BWD
RF1-MD1X45								
Open View Full-Free Lift Three-Stage Mast (FSW)	187 (4750)	87 (2210)	223 (5664)	43 (1092)	86.75 (2203)	75.5 (1917)	3	4.5
	211 (5359)	95 (2413)	247 (6274)	53 (1346)	94.75 (2407)	83.5 (1835)	3	4.5
	226 (5740)	102 (2591)	262 (6655)	50 (1270)	95 (2413)	83.75 (2127)	3	4.5
	250 (6350)	110 (2794)	286 (7264)	61 (1549)	90.8 (2306)	79.55 (2020)	3	4.5
	268 (6807)	118 (2997)	304 (7722)	69 (1753)	90.8 (2306)	79.55 (2020)	3	4.5

¹ Tilting Load Backrest.
NOTE: Height of standard load backrest is 36 in (914 mm).



WORLD-CLASS MATERIAL HANDLING SOLUTIONS

PARTNER WITH TOYOTA, AND LET US HELP DEVELOP THE RIGHT SOLUTION FOR YOU.

With access to the world's industry-leading lineup of material handling products, Toyota dealers are uniquely positioned to help you solve your wide-ranging challenges. Built for every application, Toyota can provide the most complete set of solutions for material handling, automation, energy, advanced logistics, and warehouse optimization.

Toyota is here to help optimize your business for maximum efficiency. Utilizing Toyota Lean Management principles, Toyota dealers can provide insights and develop appropriate plans to tackle your specific operational needs. This unique approach to optimization and elimination of waste can provide you with significant competitive advantages and a sustainable lean culture for lasting process improvement.

Visit us at: ToyotaForklift.com for more information.

